



Diaphragm Valve

T7

PVC-U

DATASHEET

Diaphragm Valve T7

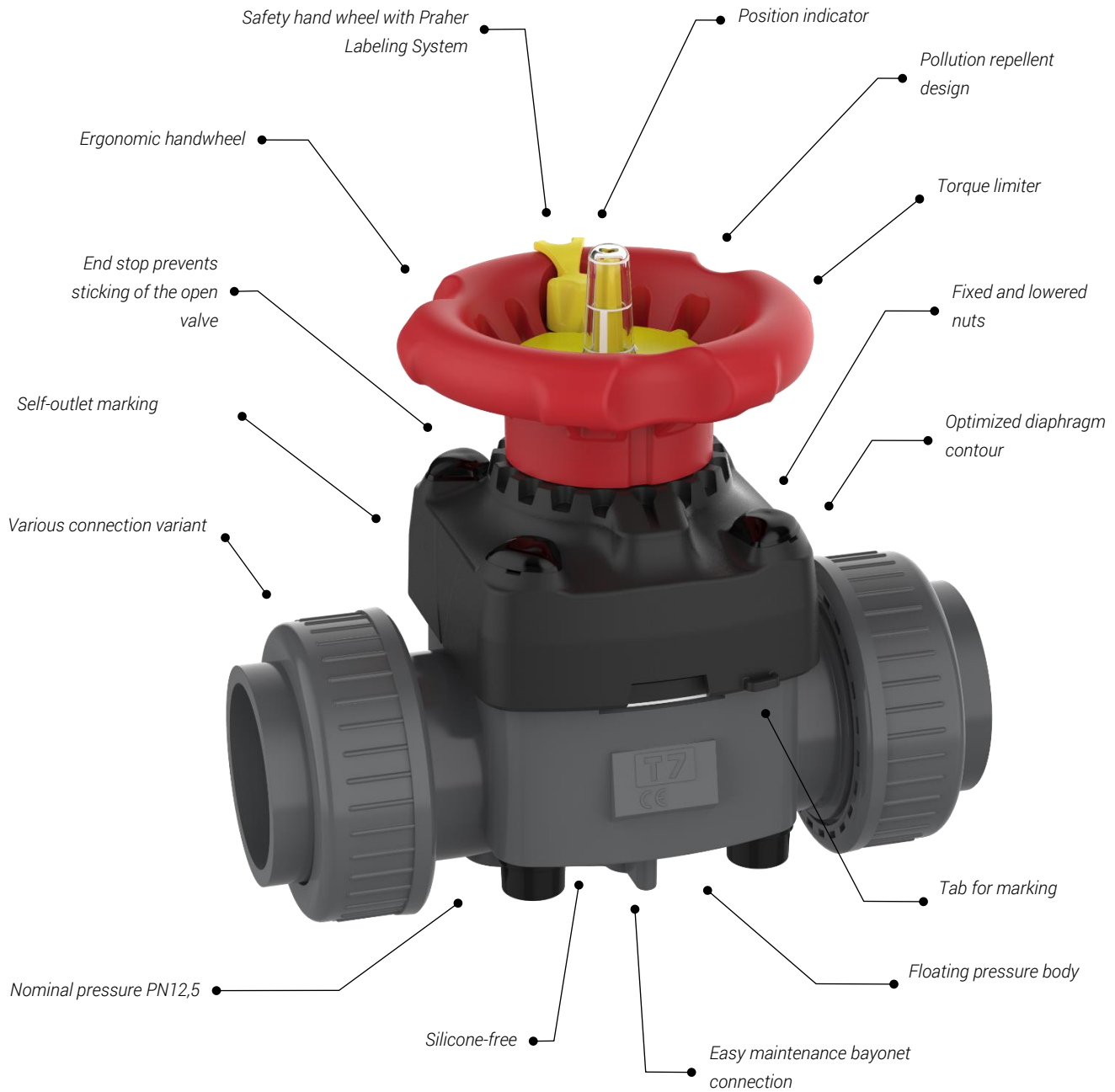

© European Union 008392252-0001 to -0006

Overview

General			
Materials	Body material	PVC-U	
	Seal material	EPDM / FPM	
	Diaphragm	EPDM / EPDM+PTFE / FPM	
Dimensions	DN15 – DN50 d20 – d63 1/2" – 2"		
Connection Variants	PVC-U spigot	metric	SDR11 / PN16
	PVC-U fixed flange	DIN / ANSI / JIS	PN16
	<u>Inserts for union:</u>		
	PVC-U socket ends	metric / ASTM / JIS	
	PVC-U thread socket	BSP	G- Norm Thread
	PE100 fusion spigot	metric	SDR11 / PN16
	PE100 fusion spigot long	metric	SDR11 / PN16
	PE100 fusion socket	metric	
Operating Variants	Handwheel Torque limited		
	Handwheel		
Operating Pressure	DN15 – DN50 Diaphragm EPDM	PN12,5	
	DN15 – DN50 Diaphragm EPDM + PTFE	PN12,5	
	DN15 – DN50 Diaphragm FPM	PN10	

Table of Contents



Technical Data

Page 5



Manually Operated Diaphragm Valve

Page 7



Accessories / Spare Parts

Page 16

Technical Data

Pressure-Temperature-Diagram

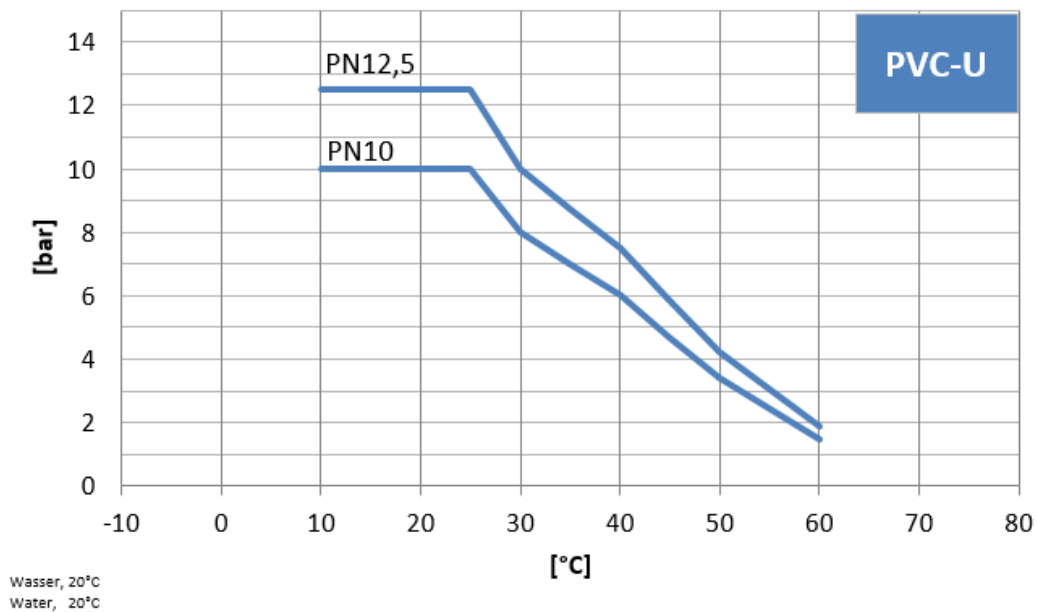

The values of the pressure-temperature diagram are based on a service life of 25 years at static pressure load with water at 20°C

Torque at Handwheel to Reach Closed Position

Dimension	Torque Handwheel [Nm]	
	EPDM – FPM	EPDM/PTFE
DN 15/20	3	5
DN25	4	5
DN32/40	12	16
DN50	16	19

Torque on the Connecting Screws of the Upper and Lower Part

Screw Torque	
Dimension	[Nm]
DN 15/20	4
DN25	5
DN32/40	10
DN50	13

For further information and notes, see operating instructions.

Technical Data

Flow - Pressure Drop

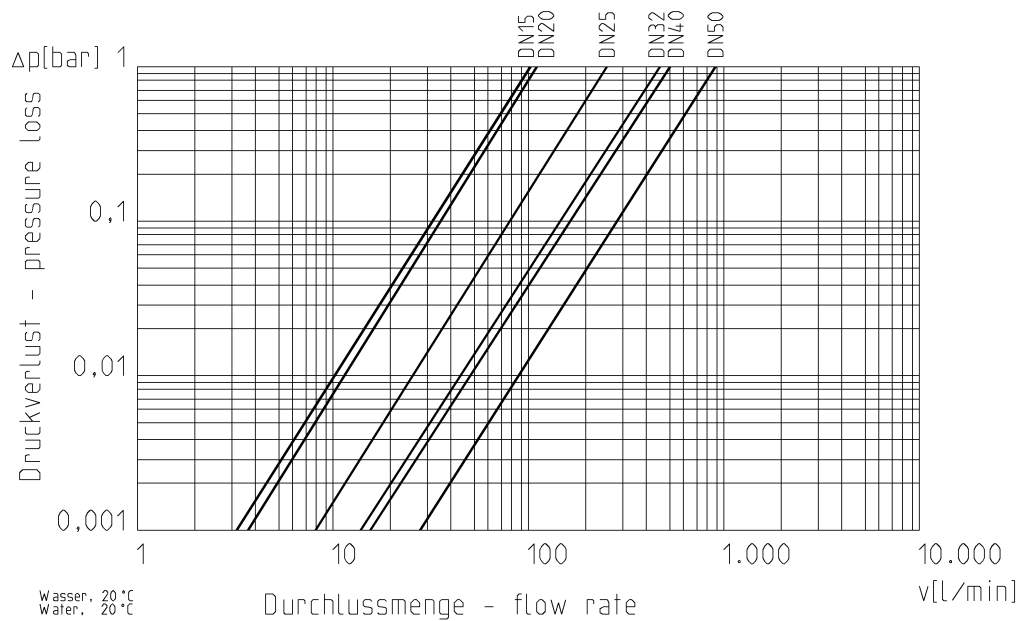

CV-Value-Table

Pressure Loss	DN15 d20	DN20 d25	DN25 d32	DN32 d40	DN40 d50	DN50 d63
0,001 bar	3,2	3,6	7,9	14,2	15,8	27,8
1 bar	102	114	250	450	500	880

Figures in l/min (PN10 pipe)

Flow characteristics

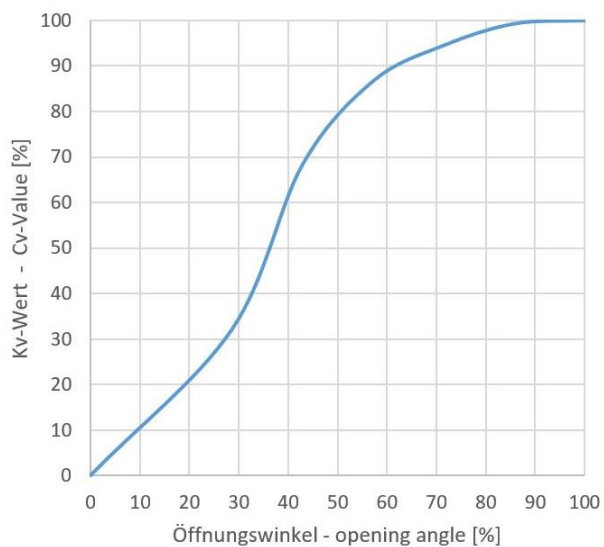

Dimensions Manually Operated Valve

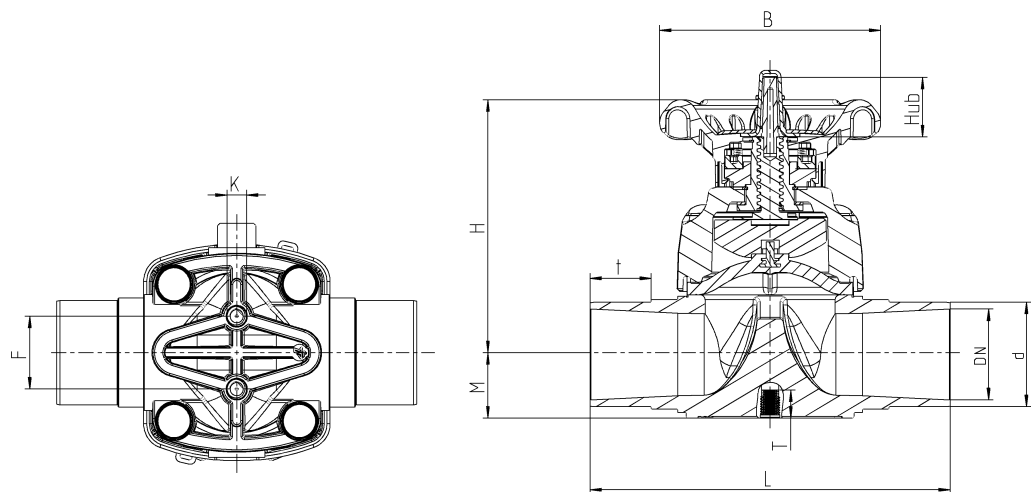

Connection Variant

PVC-U Solvent Spigot Metric

DN	15	20	25	32	40	50
d	20	25	32	40	50	63
Inch	1/2"	3/4"	1"	1 1/4"	1 1/2"	2"
H	87	89	96	135	140	153
B	85	85	85	138	138	138
F	25	25	25	44	44	44
K	M6	M6	M6	M8	M8	M8
Hub	13	13	15	22	22	30
t	16	19	22	36	33,5	38
L	124	144	154	174	194	224
M	18,6	16,5	20	25,5	32	39,5

(Dimensions in mm)

Dimensions Manually Operated Valve

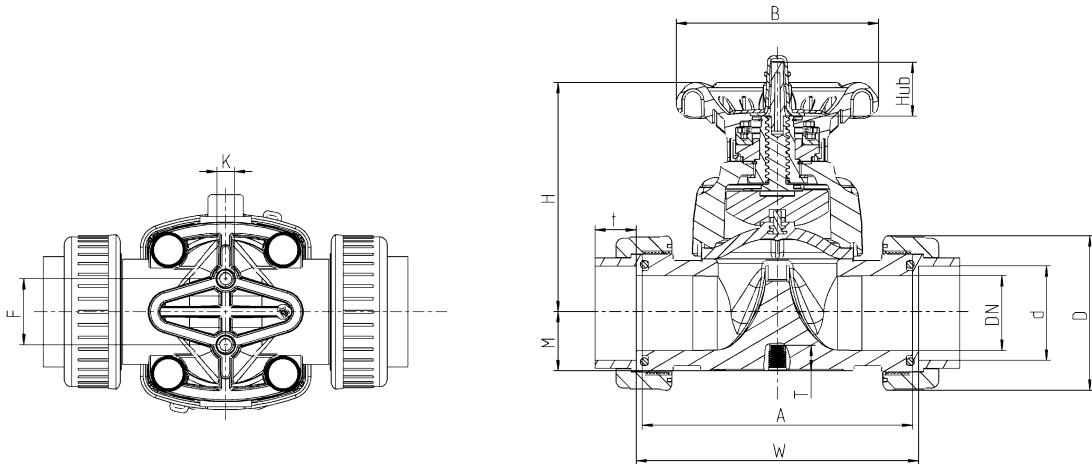

Connection Variant

PVC-U Solvent Socket Metric / ASTM / JIS via Union

DN	15	20	25	32	40	50
d	20	25	32	40	50	63
Inch	1/2"	3/4"	1"	1 1/4"	1 1/2"	2"
H	87	89	96	135	140	153
B	85	85	85	138	138	138
F	25	25	25	44	44	44
K	M6	M6	M6	M8	M8	M8
Hub	13	13	15	22	22	30
t _{metr.}	17	18,5	22	27	27	28
t _{ASTM}	16.5	19.5	23	27	31,5	39
t _{JIS}	17	19,5	22,5	27	31,5	*
A	90	108	116	136	154	184
D	44	53	60	74	83	103
M	18,6	16,5	20	25,5	32	39,5
W _{metr}	96	115	122	142	171	192
W _{ASTM}	95	115	122	142	160	190
W _{JIS}	96	115	123	142	160	*

* on request

(Dimensions in mm)

Dimensions Manually Operated Valve

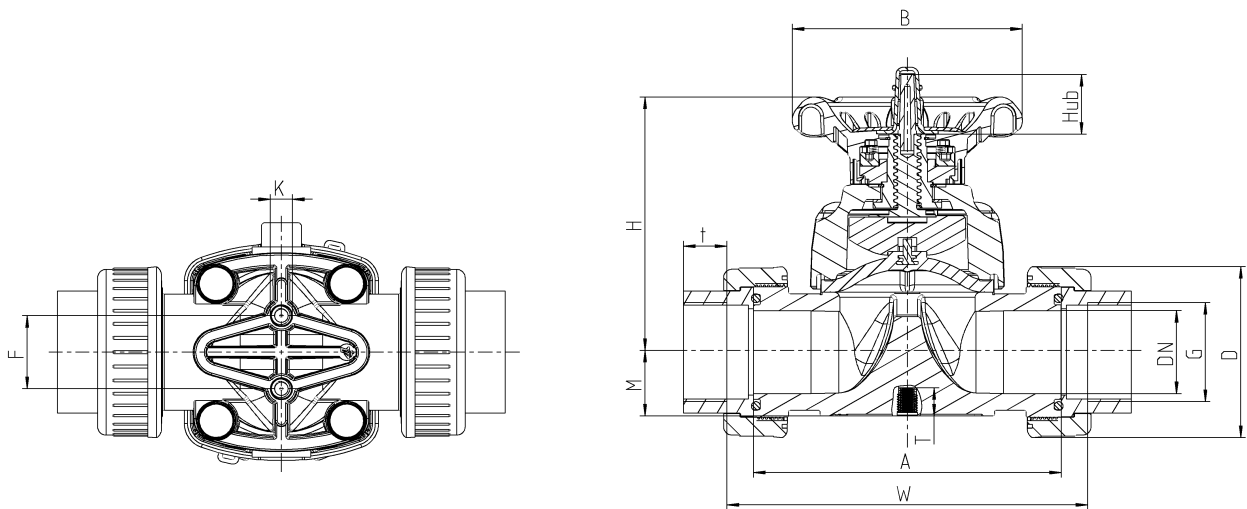

Connection Variant

PVC-U Threaded Socket BSP via Union

DN	15	20	25	32	40	50
d	20	25	32	40	50	63
Inch	1/2"	3/4"	1"	1 1/4"	1 1/2"	2"
H	87	89	96	135	140	153
B	85	85	85	138	138	138
F	25	25	25	44	44	44
K	M6	M6	M6	M8	M8	M8
Hub	13	13	15	22	22	30
t	16.5	18.5	18,5	22	22	26
W	97	115	129	152	180	216
M	18,6	16,5	20	25,5	32	39,5
A	90	108	116	136	154	184
D	44	53	60	74	83	103

(Dimensions in mm)

Dimensions Manually Operated Valve

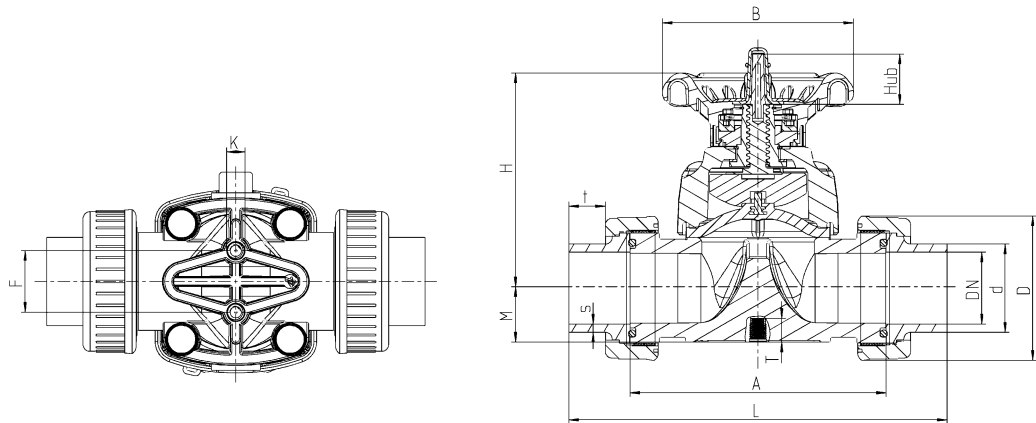

Connection Variant

PE Fusion Spigot Metric via Union

DN	15	20	25	32	40	50
d	20	25	32	40	50	63
Inch	1/2"	3/4"	1"	1 1/4"	1 1/2"	2"
H	87	89	96	135	140	153
B	85	85	85	138	138	138
F	25	25	25	44	44	44
K	M6	M6	M6	M8	M8	M8
Hub	13	13	15	22	22	30
t	14	16	18	15	29	26
L	150	180	194	194	240	272
M	18,6	16,5	20	25,5	32	39,5
A	90	108	116	136	154	184
D	44	53	60	74	83	103
s	2,1	2,5	3,1	3,7	5,2	5,8

(Dimensions in mm)

Dimensions Manually Operated Valve

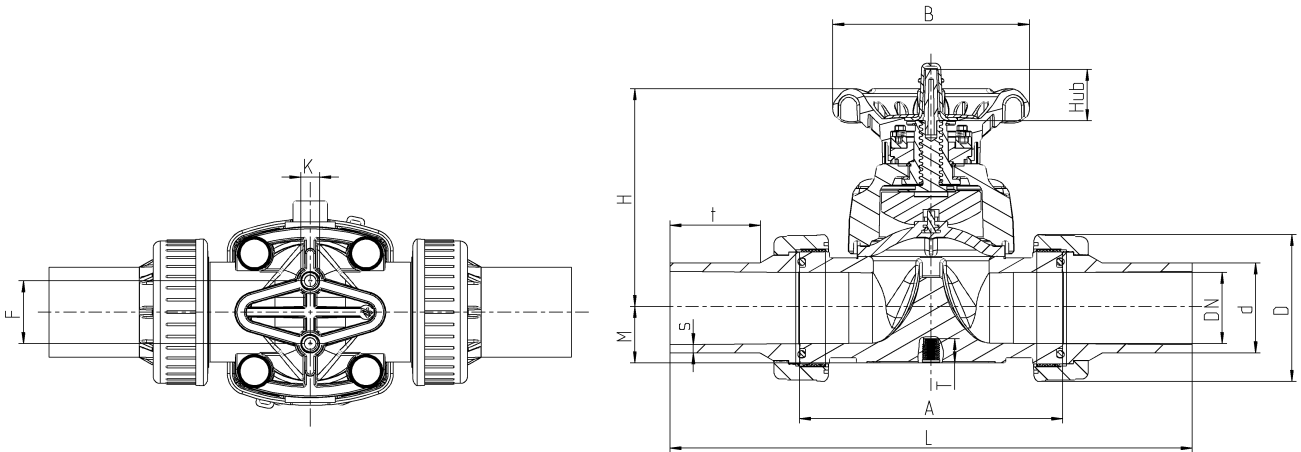

Connection Variant

PE Fusion Spigot Long Metric via Union

DN	15	20	25	32	40	50
d	20	25	32	40	50	63
Inch	1/2"	3/4"	1"	1 1/4"	1 1/2"	2"
H	87	89	96	135	140	153
B	85	85	85	138	138	138
F	25	25	25	44	44	44
K	M6	M6	M6	M8	M8	M8
Hub	13	13	15	22	22	30
t	46	47	71,5	55	59,5	63
L	214	245	286	294	323	365
M	18,6	16,5	20	25,5	32	39,5
A	90	108	116	136	154	184
D	44	53	60	74	83	103
s	3	3	2,9	3,7	4,6	5,8

(Dimensions in mm)

Dimensions Manually Operated Valve

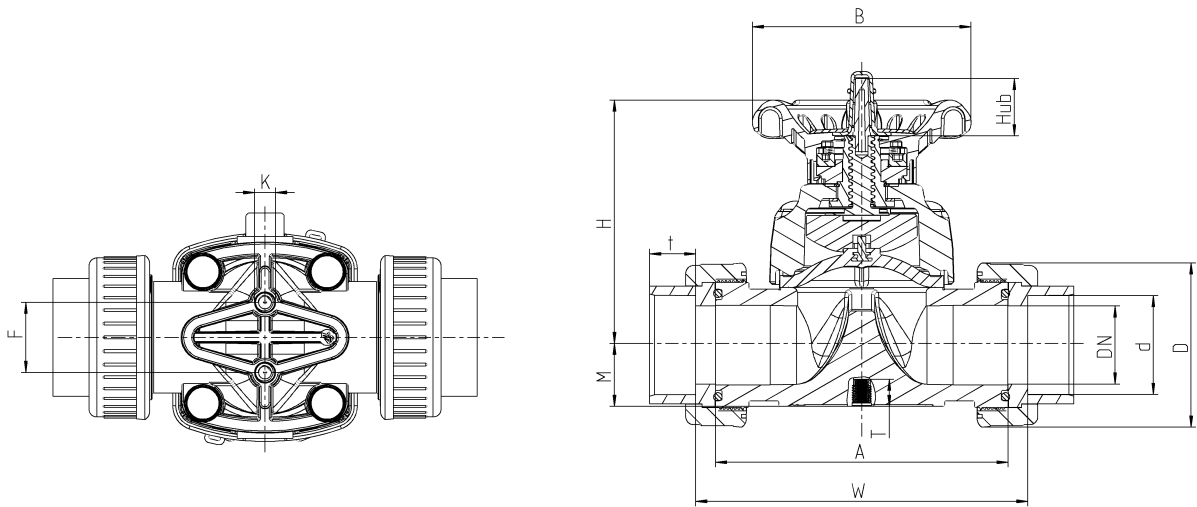

Connection Variant

PE Fusion Socket Metric via Union

DN	15	20	25	32	40	50
d	20	25	32	40	50	63
Inch	1/2"	3/4"	1"	1 1/4"	1 1/2"	2"
H	87	89	96	135	140	153
B	85	85	85	138	138	138
F	25	25	25	44	44	44
K	M6	M6	M6	M8	M8	M8
Hub	13	13	15	22	22	30
t	16	17,5	19,5	22	25	29
W	95	116	126	148	173	209
M	18,6	16,5	20	25,5	32	39,5
A	90	108	116	136	154	184
D	44	53	60	74	83	103

(Dimensions in mm)

Dimensions Manually Operated Valve

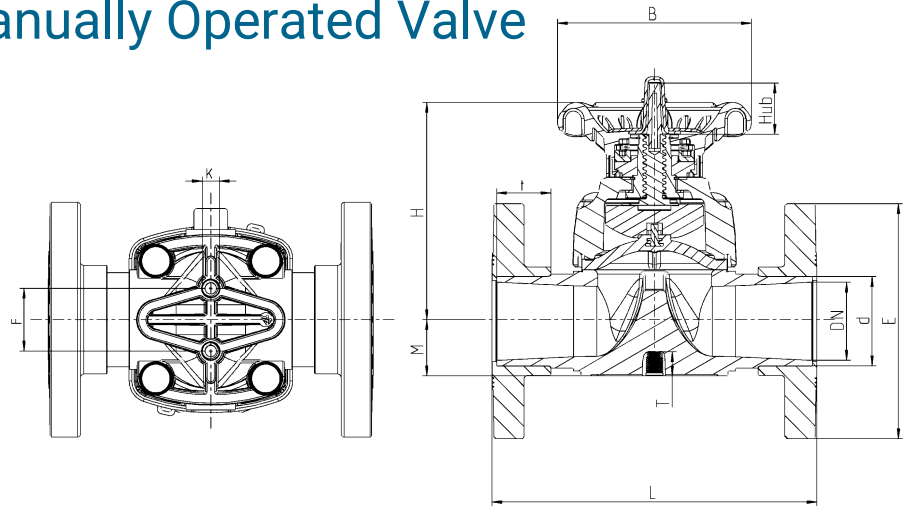

Connection Variant

PVC-U Fixed Flange DIN-ANSI-JIS

DN	15	20	25	32	40	50
d	20	25	32	40	50	63
Inch	1/2"	3/4"	1"	1 1/4"	1 1/2"	2"
H	87	89	96	135	140	153
B	85	85	85	138	138	138
F	25	25	25	44	44	44
K	M6	M6	M6	M8	M8	M8
Hub	13	13	15	22	22	30
L	131	151	162	180	200	230
E	97	105	125	140	150	165
M	18,6	16,5	20	25,5	32	39,5

(Dimensions in mm)

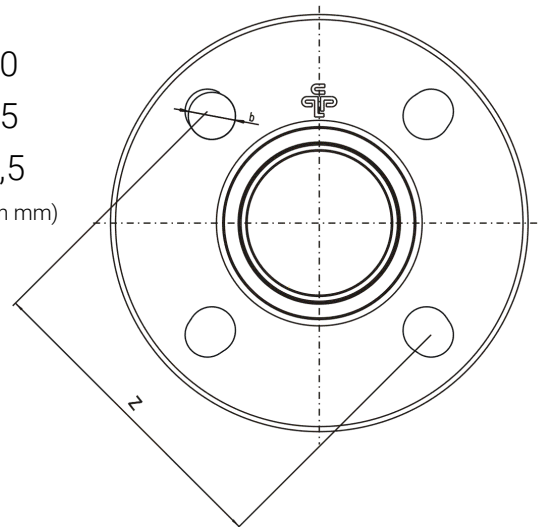

Screw Connection Diagram Fixed Flange

Multinorm DIN-ANSI-JIS

Norm	DN	15	20	25	32	40	50
	d	20	25	32	40	50	63
	Inch	1/2"	3/4"	1"	1 1/4"	1 1/2"	2"
DIN 2501	b	14	14	14	18	18	18
	Z	65	75	85	100	110	125
ANSI Class 150	b	15,5	15,5	15,5	15,5	15,5	19
	Z	60,3	69,8	79,3	89	98,5	120,6
JIS 10 k	b	15	15	19	19	19	19
	Z	70	75	90	100	105	120

(Dimensions in mm)

EXPLOSION DRAWING

with Torque Limiter

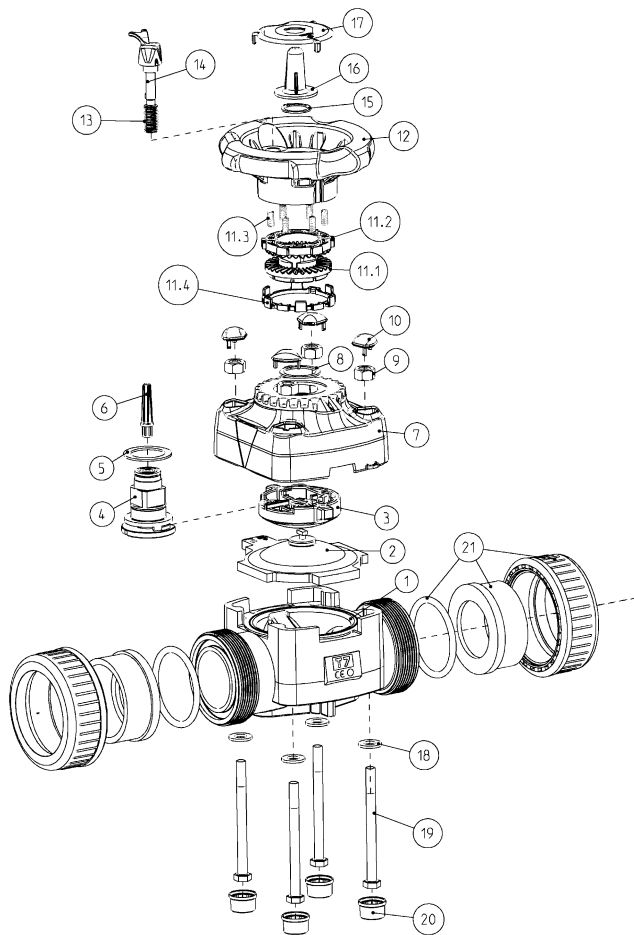

No.	Description	Material
1.	Lower part	PVC-U
2.	Diaphragm	EPDM FPM EPDM+PTFE
3.	Pressure body	PP-GF
4.	Spindle assembly	Brass & 1.4305
5.	Sliding washer	PTFE
6.	Indicator pin	PS
7.	Upper part	PP-GF
8.	Circlip	A4
9.	Hexagon nut	PTFE-coated
10.	Cover cap	ABS
11.	Torque Limiter	
11.1.	Lower part	POM
11.2.	Upper part	PA
11.3.	Spring	1.4310
11.4.	Support- Ring (DN32-50)	ABS
12.	Handwheel	PP-CF
13.	Spring	1.4401
14.	Latch pin	PBT
15.	Circlip	Galvanized spring steel
16.	Inspection glass	ABS
17.	Inspection glass Holder	ABS
18.	Rip-Lock washer	A4
19.	Hexagon screw	A2
20.	Cover cap	PE
21.	Connection variant Union	
	O-Ring	EPDM / FPM
	Union nut	PVC-U
	Solvent socket	PVC-U
	Thread socket	PVC-U
	PE spigot	PE
	PE socket	PE

EXPLOSION DRAWING

without Torque Limiter

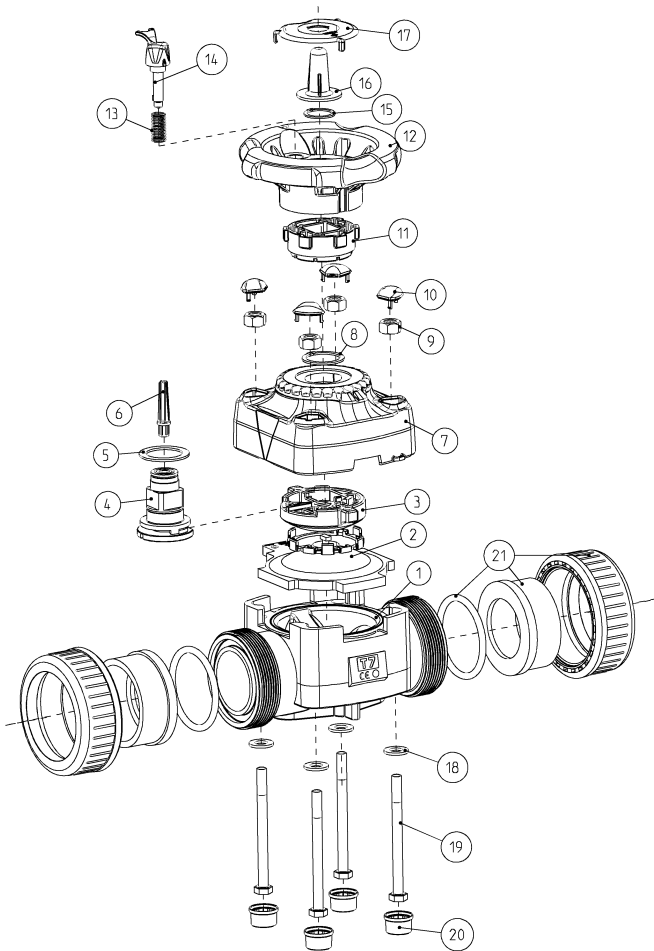

No.	Description	Material
1.	Lower part	PVC-U
2.	Diaphragm	EPDM FPM EPDM+PTFE
3.	Pressure body	PP-GF
4.	Spindle assembly	Brass +1.4305
5.	Sliding washer	PTFE
6.	Indicator pin	PS
7.	Upper part	PP-GF
8.	Circlip	A4
9.	Hexagon nut	PTFE-coated
10.	Cover cap	ABS
11.	Actuating unit PP-CF	
12.	Handwheel	PP-CF
13.	Spring	1.4401
14.	Latch pin	PBT
15.	Circlip	Galvanized spring steel
16.	Inspection glass	ABS
17.	Inspection glass Holder	ABS
18.	Rip-Lock washer	A4
19.	Hexagon screw	A2
20.	Cover cap	PE
21.	Connection variant Union	
	O-Ring	EPDM / FPM
	Union nut	PVC-U
	Solvent socket	PVC-U
	Thread socket	PVC-U
	PE spigot	PE
	PE socket	PE

ACCESSORIES / Spare Parts

Handwheel Unit

With Torque Limiter DN15 – DN50

With Marking at Handwheel (see sketch detail)

Consisting of:

- Handwheel
- Torque – Limiter elements
- Latch pin + Spring
- Circlip
- Inspection glass
- Inspection glass holder

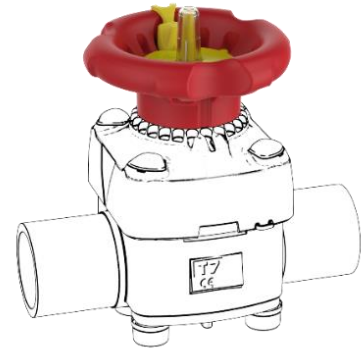

Handwheel Versions:

1 Version = DN15/DN20/DN25 for EPDM, FPM and PTFE Diaphragm

2 Version = DN32/DN40 for EPDM and FPM Diaphragm

3 Version = DN32/DN40 for PTFE Diaphragm

4 Version = DN50 for EPDM and FPM Diaphragm

5 Version = DN50 for PTFE Diaphragm

Without Torque Limiter DN15 – DN50

Without Marking at Handwheel (see sketch detail)

Consisting of:

- Handwheel
- Actuating unit
- Latch pin + Spring
- Circlip
- Inspection glass
- Inspection glass holder

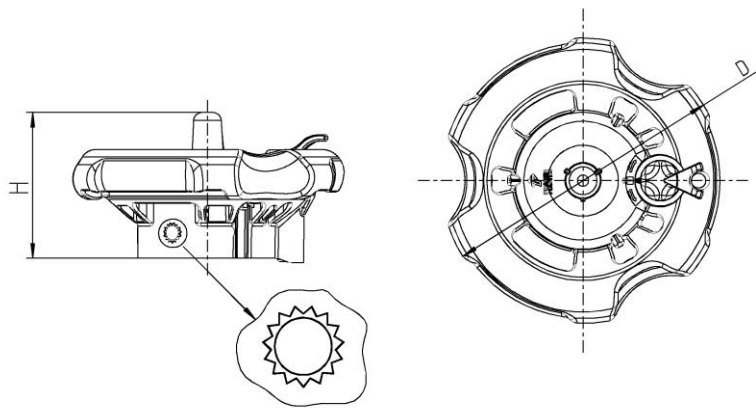

Handwheel Versions:

6 Version = DN15/DN20/DN25

7 Version = DN32/DN40/DN50

DN	15 – 25	32 – 50
d	20 – 32	40 – 63
Inch	1/2" – 1"	1 1/4" – 2"
D	85	138
H	42	70

(Dimensions in mm)

ACCESSORIES / Spare Parts

Upper part assembly

Consisting of:

- Pressure body
- Spindle assembly
- Sliding washer
- Indicator pin
- Upper part
- Circlip
- Hexagon nut
- Cover cap (No. 10)



Upper part Versions:

- 1 Version = DN15/DN20
- 2 Version = DN25
- 3 Version = DN32/DN40
- 4 Version = DN50

Diaphragm

- Material: EPDM / FPM
- Bayonet connection
- Optimized contour

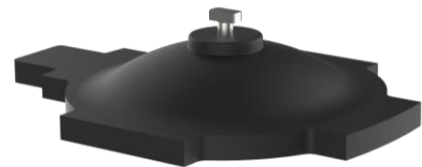

Coated Diaphragm

- Material: EPDM PTFE coated
- Bayonet connection
- Optimized contour



ACCESSORIES / Spare Parts

Accessories / Spare Parts for Union Variant

Union End / Union Nut / Connection O-Ring

- The Union end, Union nut and O-Rings from the PVC-U IBG range for Unions, can be combined with the same nominal diameter of the Diaphragm valves with Union.

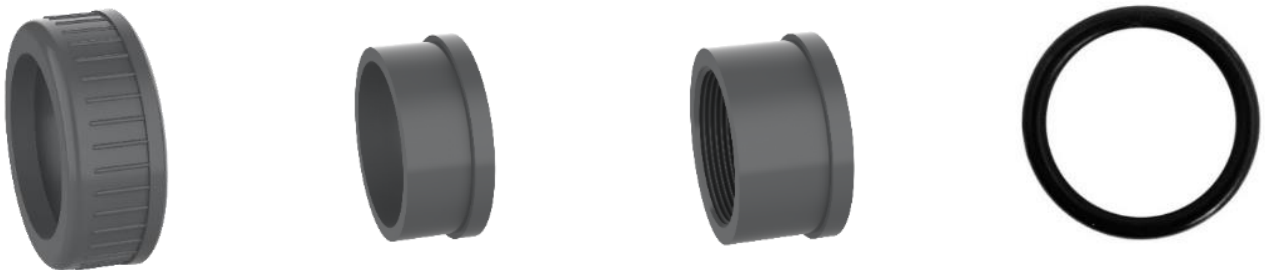

PLS – Praher Labeling System

Features

- Material ABS
- Unique permanent marking
- Reliable, indelible marking by paint pen or laser
- Standard version in the colors yellow, blue, green and red
- Marking plates are simple to replace
- Corrosion resistant
- No effect on the function of the handle



ACCESSORIES / Spare Parts

Mounting Plates

Use as mounting aid and height compensation.

- Material: PP-CF
- Floor / ceiling / wall -mounting
- Additional screws necessary

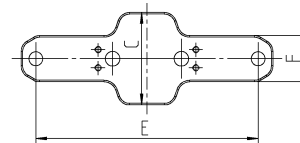
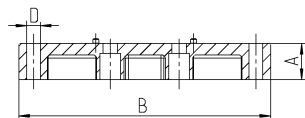

DN	15 - 25			32 - 50		
d	20 - 32			40 - 63		
Inch	1/2" - 1"			1 1/4" - 2"		
Version	1	2	3	4	5	6
A	23	16	3,5	23,5	18,5	7,5
B	104	104	104	164,5	164,5	164,5
C	45	45	45	60	60	60
D	7	7	7	9	9	9
E	90	90	90	145,5	145,5	145,5
F	22	22	22	30	30	30

(Dimensions in mm)

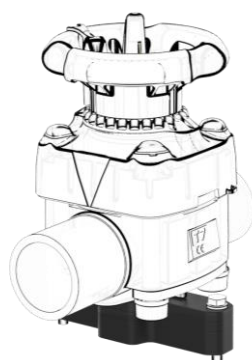

Note on the Use of Mounting Plates:

The table shows the number of mounting plates (e.g. 1x) and the mounting plate version (e.g. **2**).

These combinations can be used to compensate for height differences between the various nominal diameters from the M1 ball valve to the T7 diaphragm valve.

		Ball Valve M1								
		G[mm]	33	40	43	51	56	64	85	100
H [mm]		DN	15	20	25	32	40	50	65	80
Diaphragm Valve T7	18,6	15	1x 2 	1x 1 	1x 1 1x 3	1x 1 3x 3	2x 2 2x 3	2x 1 	4x 2 1x 3	5x 2 1x 3
	16,5	20		1x 1 	1x 1 1x 3	1x 1 3x 3	2x 2 2x 3	2x 1 	4x 2 1x 3	5x 2 1x 3
	20	25			1x 1 	1x 1 2x 3	2x 2 1x 3	1x 1 1x 2 1x 3	4x 2 	3x 1 3x 3
	25,5	32				1x 4 	1x 4 1x 6	1x 4 2x 6	2x 5 3x 6	1x 4 2x 5 2x 6
	32	40					1x 4 	1x 4 1x 6	2x 5 2x 6	1x 4 2x 5 1x 6
	39,5	50						1x 4 	1x 4 3x 6	1x 4 2x 5

Examples for all nominal diameters of the Diaphragm Valve T7 combined with a Ball Valve M1 DN80:

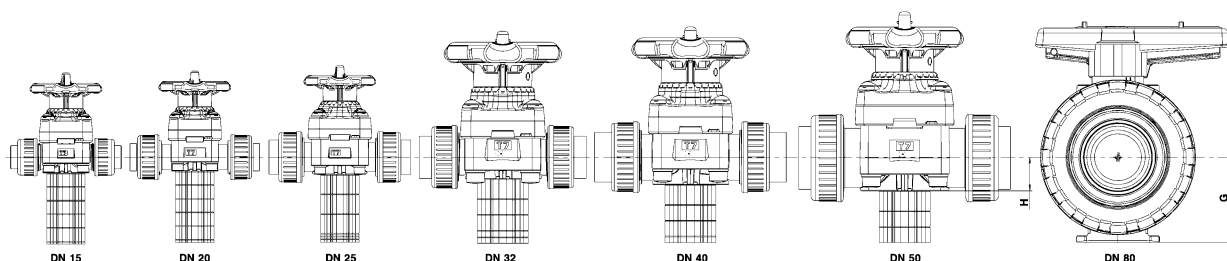



Praher Plastics Austria GmbH

Poneggenstraße 5
4311 Schwertberg
Österreich

T +43 7262 61179-0
F +43 7262 61203
sales@praherplastics.com

© Praher Plastics Austria GmbH
Zertifiziert nach / certified acc. to
EN ISO 9001:2015

PM LD 4.2-001A DEEN
DB/EN/22/07/459/B

This publication does not contain any warranty commitments, but is intended only to provide information. The program is constantly being expanded, therefore the designs and types correspond to the status at the time of printing. We reserve the right to make technical changes!



www.praher-plastics.com